3-Way Active Crossover

Model XOVER-3

Assembly and Operator's Manual

Rev 1.01

Xkitz.com

Features

- 3-way Active Crossover for driving separate subwoofer, midrange and tweeter amplifiers
- Linkwitz-Riley crossover, 4th order, 24dB/Octave roll-off
- Perfect for Tri-Amping your sound system
- Crossover frequency configuration components are on two socketed modules - quick and easy to change the XO frequencies by simply snapping in new modules
- Wide range of standard XO frequency modules are offered by Xkitz
- Baffle Step Compensation, optional, adjustable and configurable to support various baffle sizes
- Supports unbalanced signal inputs/outputs by default, support for balanced audio signaling is available as an add-on option.
 - Unbalanced signals are connected via standard RCA jacks
 - Balanced signals are connected via optional 3.5mm TRS jacks
- Specifications:
 - Mid/High THD, THD+N: < 0.070%, < 0.088%
 - Sub-Woofer THD, THD+N: < 0.0020%, < 0.020%
 - Frequency Response: Linear from 10Hz - 80KHz
 - CMRR (balanced input): > 55dB
 - Input Impedance: 20K ohms unbalanced, 40K ohms balanced
 - Input Overload: 3.8V peak-to-peak
 - Voltage Gain: Adjustable Sub, Mid and High, Max 0dB Unbal, 12dB Balanced
 - Filter Topology: Linkwitz-Riley, Constant Voltage, 4th Order, 24dB/Octave
 - Power supply: 17V-24V DC, Single positive DC rail (no negative supply required)
 - Supply Current: 150mA
- Channels are phase aligned to within a fraction of a degree to minimize distortion near the XO frequency
- Separate Sub, Mid and High output level adjustments via on-board multi-turn trim-pots
- Filtered LDO regulator for high power supply noise rejection, ultra clean audio
- This is a mono device, two units are needed for stereo operation
- PCB dimensions: 4.125" x 2.5" x 0.65" height
- This is an intermediate electronic kit containing 80 components, and can be assembled in about 2 hours

What's an Active Crossover and Why Do I Need It?

Most speaker boxes have an electronic circuit inside them called a crossover. Its job is to split the sound into frequency ranges; it sends the low frequency sounds to the woofer, and the high frequency sounds to the tweeter. This is important because each of the loudspeakers is built to produce certain frequency ranges, and they don't sound very good outside of their proper range.

In fact, loudspeakers can actually distort within their natural frequency range if they are also presented with frequencies outside their natural range. In other words if you send low frequencies to your tweeter, the high frequency sound reproduced by the tweeter will be distorted by the presence of the low frequency signal.

When you separate the frequencies with a crossover, each loudspeaker is able to focus on producing only the frequencies that they're designed to produce.

Most speaker boxes you see have **passive crossovers**, which are made up of some inductors and capacitors that filter the low frequencies from the highs. But passive crossovers have a number of very significant drawbacks. One big problem with passive crossovers is they don't have a very sharp **roll-off**. This means that some of the bass frequency energy will still reach the tweeter, and some of the treble energy will still reach the woofer. Another major disadvantage with passive crossovers is efficiency; they waste a huge amount of the power your amplifier is providing. High frequency sounds are prevented from going to the woofer (and low frequencies prevented from going to the tweeter) by essentially just shorting them out; so power is wasted in the form of heat dissipated in the crossover components.

But by far the biggest problem with passive crossovers is that they significantly degrade the quality of the signals that pass through them by introducing distortion in the following ways:

- Channel phasing: Once the crossover splits the audio signal, the woofer and tweeter signals will be out of phase from each other (which means one leads or lags the other). This causes distortion at and around the crossover frequency because at these frequencies both the tweeter and the woofer will be driven, but each will be at a different phase. At various points of time in the wave the woofer and tweeter will be either fighting one another or re-enforcing one another. This leads to a muddying of the sound definition.
- Channel Cross-talk due to Back-EMF: The mass of the loudspeaker cones will continue to move in the direction they are being driven by the amplifier for a short period of time after the signal changes direction, and this induces currents in the voice coils that couple back into the passive crossover and causes unpredictable non-linear crosstalk between the channels of the crossover.
- Frequency response degradation: any time you put large capacitors and inductors in series or parallel with your audio signal it will invariably affect frequency response of the signals. The ways in which this can happen depend on the design of the crossover and the characteristics of the loudspeakers. The nature of this distortion is so complex it becomes almost impossible to accurately model.

All of this adds significant distortion to the final sound emitted. Audio engineers for decades have tried in vain to come up with ever more complex passive filter arrangements to try and resolve, or mask, these inherent problems.

An **active crossover**, like the XOVER-3, on the other hand, is built from the highest quality operational amplifiers (op-amps) and the filter functions are applied to the high impedance, line-level preamp input instead of the low impedance, high voltage level amplifier output. Active filters have a much sharper roll-off, 24dB/octave, allowing each of the loudspeakers to perfectly focus on producing just the frequencies they are designed to handle. Active crossovers are also more efficient from a power standpoint because of the fact that the filters are applied in the line-level audio input signal; only the energy meant for a particular driver is sent to the amplifier that drives it, so there is no waste. But the biggest advantage of active crossovers is the sound quality. A vanishingly small amount of noise and distortion is introduced in the op-amp filter circuits, on the order of 0.00005% total harmonic distortion.

All of this results in extremely clean, precise, and well defined audio output to your amplifiers.

Unpacking Your Kit

Carefully unpack and take stock of the components in your kit. The electronic components are packed in 2 bags labeled 'Bag A' and 'Bag B'. See Table 1 for a complete listing of your components.

Assembly Instructions

It is very important that you read and understand all of the following instructions before you start your assembly so that you don't make any mistakes that might be difficult to recover from. The assembly should be done in the order listed in Table 1 or you may have difficulty physically accessing components for soldering.

What you'll need

- Soldering iron with small or medium tip
- Damp sponge for tip cleaning
- Solder
- Solder wick or solder sucker in case of solder bridging (stranded wire could substitute)
- Small needle nose pliers.
- Small wire cutters
- Small straight screwdriver
- Sharp knife
- Magnifying glass to read the markings on the tiny components

General Assembly Guidelines

- **Take your time!!** Most mistakes are made when rushing through the assembly. Taking the time to double check every step will pay off with a first-time functional device.
- In cases where it is necessary to re-form the leads on components (such as resistors and diodes), be very careful not to put stress where the lead enters the component itself. The physical attachment of the lead to the component can sometimes be very fragile and the lead may break off if too much force is applied. Reforming the leads can be done by gripping the lead with small needle-nose pliers at the base of the component while bending the lead on the other side of the pliers.
- Use as little heat and solder as necessary to affix the components to the PCB (printed circuit board). Many of the parts in this kit are temperature sensitive. Overheating may damage them.
- Always clean the soldering iron tip on the damp sponge prior to every solder joint. Re-tin whenever the tip gets a little dull. (tinning is the application of fresh solder to the tip of the iron until its shiny, wipe excess on a damp sponge).
- Inspect the solder joints. They should be shiny and smoothly connect the pad to the lead. A dull looking joint may indicate it is 'cold', meaning that either the pad or the lead weren't heated enough to allow reliable connection. This could lead to erratic operation of the device. Re-flow the joint again with the soldering iron, apply equal heat to both the pad and the lead, apply a little more solder if needed to get a good shiny connection.
- When clipping the excess leads of the through-hole parts, don't try to clip too close to the PCB. Clip just above the solder joint to avoid fracturing the solder joint, which could lead to device failure sometime in the future.
- Carefully inspect each solder joint to make sure you didn't accidentally form a 'solder bridge', or connect two adjacent pads together. Remove solder bridges by using solder wick or a solder sucker. If the bridge is small you may be able to remove it by just reheating the joint and sliding the soldering iron across the bridge. If not, see the next step.
- If you need to remove solder from a hole (or a solder bridge) and you don't have solder wick or a solder sucker, you can use stripped stranded wire in place of solder wick. Place the stranded wire across the hole and touch the soldering iron to the wire, above the hole. As the wire heats it will melt the solder in the hole, and the melted solder will tend to wick up into the stranded wire. When the wire fills up with solder, move a clean part of the wire over the hole and repeat until the hole is clear of solder.

Circuit Board Assembly

You're ready to begin assembling your XOVER-3 circuit board. Assemble the board in the order listed in Table 1. The components for the standard kit supporting UNBALANCED signal mode are in the bags marked 'Bag A' and 'Bag B'. If you purchased the BALANCED signal mode upgrade, you will have a second bag labeled 'Balanced Mode Upgrade', which contains the components required to configure the XOVER-3 to support balanced inputs and outputs. Use the install check boxes on the right side to track your progress. The 'Install Notes' column will alert you to any special instructions (listed on the next page) for each of the components. We recommend reading and understanding all the design notes before you start your assembly.

Table 1. Parts List - Bag A and Bag B – for standard kit supporting UNBALANCED signaling

Pack √	Device	Value	Marking	Qty	Reference Designators	Install Notes	Install √
	CIRCUIT BOARD (PCB)	REV 1.0	XOVER-3	1			
	RESISTOR	1K, 1%	BRN-BLK-BLK-BRN-BRN	12	R1,R6,R8,R10, R15,R17,R27, R30,R35,R36, R37,R39		
	RESISTOR	10K, 1%	BRN-BLK-BLK-RED-BRN	1	R26	1	
	RESISTOR	10K, 1%	BRN-BLK-BLK-RED-BRN	3	R18,R21,R24	2	
	RESISTOR	20K, 1%	RED-BLK-BLK-RED-BRN	2	R16,R25	2	
	RESISTOR	15, 1/2W	BRN-GRN-BLK-GLD-BRN	1	R38		
	CAPACITOR	100pF	101	1	C15		
	CAPACITOR	0.1uF, 10%	104	6	C33,C34,C35, C38,C39,C40		
	CAPACITOR	10uF, 10%	106 (BLUE COLORED)	10	C1,C2,C8, C14,C16,C17, C24,C30,C36, C37		
	CAPACITOR	0.015uF, 5%	153 (BLUE COLORED)	20	C3,C4,C5,C6, C7,C9,C10, C11,C12,C13, C18,C19,C20, C21,C23,C25, C26,C27,C28, C29		
	CAPACITOR		BSC Configuration Cap: One of: (See Table 3) .022uF 223 .033uF 333 .047uF 473	1	C22	3	
	SOCKET – 14 PIN			4	U1,U2,U3,U5	4	
	SOCKET – 8 PIN			1	U4	4	
	SOCKET – 20 PIN			2	XO MODULE	5	
	COMPONENT CARRIER – 20 PIN			2	XO MODULE	5	
	TRIMPOT	10K	R10K	4	VR1,VR2,VR3, VR4	6	
	ELECTROLYTIC CAPACIT.	100uF	100uF	2	C31C32	7	
	RCA JACK			4	J1,J4,J7,J8	8	
	TERM BLOCK 2			1	J10	9	
	VOLTAGE REGULATOR	LM2940CT	LM2940CT	1	U6	10	
	OP AMP CHIPS	TL074/ OPA4227	TL074 or OPA4227	3	U1,U2,U3,U5	11	
	OP AMP CHIPS	TL072/ OPA2227	TL072 or OPA2227	1	U4	11	

Table 2. Parts List – Balanced Mode Upgrade – for the optional BALANCED signaling upgrade

Pack √	Device	Value	Marking	Qty	Reference Designators	Install Notes	Install √
	RESISTOR	10K, 0.1%	BRN-BLK-BLK-RED-VIO	3	R18,R21,R24	2	
	RESISTOR	20K, 0.1%	RED-BLK-BLK-RED-VIO	2	R16,R25	2	
	3.5MM TRS JACKS			4	J2,J5,J6,J9	8	

Circuit Board Component Installation Notes:

1. You will have extra 10K resistors after this step. These extras will be used in the next step.
2. Install the 1% tolerance 10K and 20K resistors included in the standard kit ONLY if you're running in UN-BALANCED input signal mode. If you purchased the optional BALANCED mode upgrade, then discard these 1% 10K and 20K resistors, and install the 0.1% tolerance 10K and 20K resistors included in your upgrade packet instead.
3. To configure the Baffle Step Compensation circuit, install the appropriate cap value in C22. There are 3 possible cap values to install for C22, depending on your baffle size. See Table 3 below.
4. Solder the three 14 pin sockets into the PCB to hold the op amps. Align the notches on one end of the sockets to the notches shown on the PCB silkscreen.
5. Install the two 20 pin sockets in the locations on the board marked 'MID/HIGH XO' and 'SUB XO'. Install with the pin 1 notch toward chamfered corner at the top of the MODULE. Carefully insert the 20-pin component carriers into the 20-pin sockets. Solder the 10 resistors included in the XO component packs for the Mid/High and Sub XO to the component carriers to configure your crossover frequencies. Use the parts placement diagram below and the instruction slip in your XO component packs to assemble the Modules. The 10 resistors in each pack are simply inserted across the appropriate component carrier and slipped into the two horizontally adjacent, fork shaped pins. When you've double checked they're all in the correct locations, solder them in place. Cut the excess leads.
6. Install the multi-turn trim-pots in the orientation shown on the PCB pattern.
7. The electrolytic capacitors are polarized devices, be sure to install them the right way around. The positive lead is longer than the negative lead. The positive lead goes in the square pad hole on the PCB. Note that the polarity is also marked on the outer casing of the cap.
8. Install the RCA jacks in locations J1, J4, J7, and J8 ONLY if running in the stock UN-BALANCED mode. If you purchased the optional BALANCED mode upgrade, then discard the RCA jacks and install the 3.5mm jacks included in your upgrade packet in locations J2, J5, J6, and J9 instead. Note that the PCB hole patterns for the RCA jacks and the 3.5mm jacks overlap on the PCB. This is not a problem, since the RCA's and 3.5mm's are used mutually exclusively.
9. Install the terminal block so the wire openings face outward
10. The LM2940CT LDO voltage regulator is polarized. Install this with the metal heat sink tab toward the edge of the PCB as shown on the silk pattern.
11. Install the TL074 op amp chips (or the OPA4227 chips if you've purchased this upgrade) into the sockets. The op amp chips are polarized devices, installing them backward will permanently damage the devices. Align the notch on one end of the op amp chips to the notches shown on the PCB silkscreen. Be careful not to bend the leads on the op-amp chips when inserting into the sockets.

Figure 1. PCB Parts Placement and Dimensions

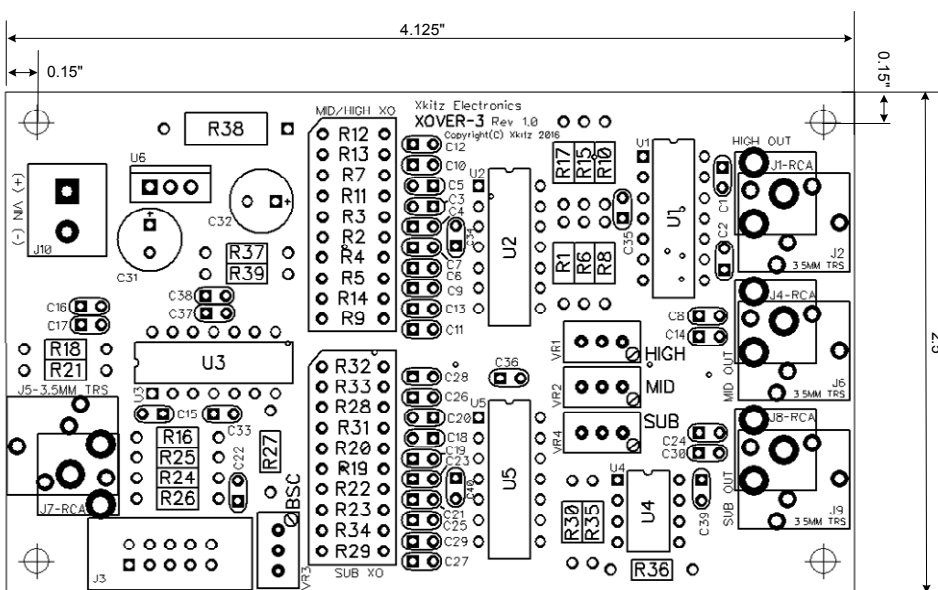

Vertical Clearance: 0.65"

Input Signal Configuration – Balanced or Unbalanced

There are two basic systems used to connect the audio signal on consumer and pro audio equipment; unbalanced lines and balanced lines. Unbalanced lines use one wire for signal and the other for ground. Balanced lines, on the other hand, have two signal wires and a shield ground wire.

Unbalanced lines are most common in consumer grade audio, and are generally much more susceptible to audio noise like 50/60Hz hum. Unbalanced lines will also pick up any electro-magnetic noise in the nearby environment (such as computers, cell phones, microwaves, etc.) and adds it to your audio signal, making it audible in your speakers. Unbalanced lines can also lead to ground loops, which are the major source of 50/60Hz hum in your sound system. Ground loops arise whenever there is more than one path from any piece of audio equipment to earth ground. Your equipment will always be grounded through your AC line. Adding another path to ground through your unbalanced audio cable adds a second path to ground, and this can cause audible 50/60Hz hum.

Balanced lines are more common in high end consumer and professional audio systems and are much less susceptible to noise. Balanced lines allow you to run very long audio cables without allowing electro-magnetic noise to couple into your signal. They're also not susceptible to 50/60Hz hum; there is no connection to ground in the audio signal cable, so they can't create ground loops in your sound system.

For unbalanced signal input, you'll install the RCA jack in location J2, and leave the J1 location empty.

For balanced signal input, you'll install the 3.5mm TRS jack in location J1, and leave the J2 location empty.

Output Signal Configuration – Balanced or Unbalanced

The Sub, Mid and High output signals can also be configured to drive either balanced or unbalanced outputs.

For unbalanced signal outputs, you'll install the two RCA jacks in locations J8 and J9, and leave location J5 and J7 empty.

For balanced signal outputs, you'll install two 3.5mm TRS jacks in locations J5 and J7, and leave location J8 and J9 empty.

Figure 2. Balanced Mode signal Input and Output TRS Jack Wiring

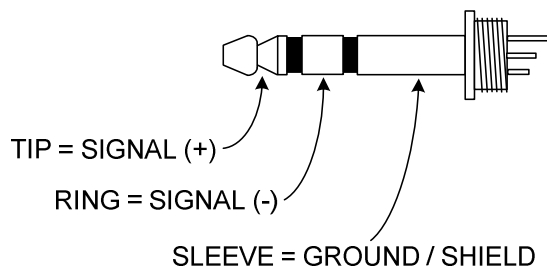

Customizing Your Active Crossover Frequency

The mid/high and subwoofer crossover (XO) frequencies are determined by the values of the resistors on the two 20-pin socketed component carriers called the 'XO Modules'. All 10 resistors on each module are set to the a particular value to control the filters' frequency responses.

Xkitz offers a wide range of standard XO Module frequencies here:

<https://www.xkitz.com/collections/active-crossovers-and-bi-amplifiers-1/products/xo-module-for-use-with-XOVER-2-and-xamps>

Or you can select your own custom XO frequency resistor values with our filter calculator tool at:

<http://www.xkitzconnect.com/files/Linkwitz-Riley-2Way-Calculator.htm>

Just enter your desired mid/high crossover frequency. Then hit the 'Calc' button. It will give you the suggested resistor value for your mid/high crossover, and it will show a schematic diagram of the crossover. Then enter the value of your chosen sub-woofer crossover frequency and hit 'Calc' again to get the values for your sub-woofer XO module. You may have to round the suggested values to standard available resistor values. High precision (1% or better) resistors are recommended to minimize distortion.

Selecting Your Ideal Crossover Frequency

Consult the specifications of your loudspeakers to select your ideal XO frequency. Every loudspeaker has its own ideal operating frequency range. Woofers, of course, work well in the low frequency range, but as frequency increases their performance deteriorates. Same for tweeters; they operate well at upper frequency ranges and deteriorate as the frequency comes down. Your crossover frequency should be somewhere near the mid-point between points where both the woofer and the tweeter are still solidly within their ideal operating frequency range.

Power Supply Requirements

The XOVER-3 requires a DC voltage source in the range of 17V up to 24V max. Even though the board has an LDO voltage regulator that will filter out most noise from your input power supply, you should try to select a power supply with a clean DC output to ensure you're audio is clean.

The XOVER-3 draws less than 150mA from the supply.

Baffle Step Compensation (BSC)

The Baffle Step Compensation circuit, or BSC, if you choose to use it, allows you to apply a low pass filter function to the audio signal to compensate for a phenomenon where sounds above a certain frequency (determined by the size of the baffle, or the front of your speaker box) are actually reflected by the front of the speaker enclosure. Sounds that fall below that frequency do not get reflected, but instead wrap around the back of the speaker enclosure. This has the effect of reducing the magnitude of the lower frequencies. Your ear hears the primary waves plus the reflected waves on the highs, but only the primary waves of the lows. The BSC circuit, by applying a low pass filter, will roll off some of the highs to restore the overall sound to a more natural, linear state. Check the web for more detailed description of BSC.

The VR3 precision 20-turn trim-pot allows the BSC magnitude to be adjusted. Turning the pot 20 full revolutions counter-clockwise reduces the BSC magnitude to the point of being entirely disabled. Turning it clockwise increases the BSC magnitude to a maximum of 6dB. In other words, it increases the amount of attenuation of the higher frequencies to 6dB below the lower frequencies. This compensates for the theoretical 6dB attenuation of the low frequencies due to the baffle step.

Table 3. Baffle Step Compensation – Recommended C22 Value

Baffle Width (in Inches)	Baffle Step Freq.	C22 Value
Less than 10"	507Hz	0.022uF
10" - 16"	351Hz	0.033uF
Greater than 16"	240Hz	0.047uF

Initial Power-up and Calibration

Before applying power for the first time, it's a good idea to make sure the Sub, Mid, High and BSC are fully disabled. The trim-pots are high precision, 20 turn pots, so in order to ensure the Sub, Mid, High and BSC are fully OFF you need to turn all three trim-pots 20 full revolutions counter-clockwise.

There are a number of different methods to calibrate a 3-way active crossover. Below is the method we generally prefer. We like to first set the Sub and Mid levels to roughly unity gain (output level same as input) using a voltmeter or an oscilloscope, then gradually raise the level of the high channel and set the ideal level exclusively by ear or a spectrum analyzer. There is generally a large difference in the efficiencies of woofers and tweeters, so there is no ideal ratio between the Sub, Mid and High levels. Using this method, you end up with an overall insertion gain of roughly 0dB, and you can easily reach an ideal balance between drivers with differing levels of efficiency.

In a stereo system, you'll want to try and calibrate both L and R at the same time to maintain a close balance of the L and R volume levels.

1. Use a signal generator of some kind to inject a sine wave into the crossover. Free signal generator apps are widely available for any smart phone or on the PC. Either connect it directly to the input of the crossover, or if your crossover is part of your larger system, simply connect it to any line input and select it to drive the crossovers.
2. Set the level of the signal generator (or the volume of your system) to maximum volume.
3. Set the frequency of the signal generator to around 50Hz.
4. Using a voltmeter or oscilloscope, measure the signal level of the crossover's input signal(s). For unbalanced inputs, just unplug the RCA jack from the crossover and measure the voltage across the inner and output contacts of the cable jack. For balanced input(s), unplug the TRS jack and measure across the TIP and RING conductors (see Fig 2 above). Plug the jack back into the crossover.
5. Begin raising the level of the Mid channel while monitoring the crossover Mid output. Again, measure across the RCA jack contacts or the TIP and RING for unbalanced or balanced modes. Raise the Mid level until the output voltage is equal to the input level from step 4.
6. Now that you have your Mid channels set to 0dB gain, it's time to set the crossover Sub and High levels. Connect your normal audio signal source and set the volume to a comfortable listening level.

Either use a spectrum analyzer (free smart phone or PC apps are available) or just use your ears to monitor the audio from your speakers. Since the HIGH levels are set to zero, the sound will start out dull and lacking in any high frequencies. Slowly raise the HIGH level control pot until your treble levels are flat on the spectrum analyzer, or until they sound natural by ear. You may want to adjust the L and R in isolation so that you can make sure both are dialed in properly, without the other channel interfering. Repeat for the Sub channel.

7. Now slowly raise the BSC pot until your bass response sounds natural, or the lows below the baffle step frequency look flat on the spectrum analyzer (see table 3).

Troubleshooting

If you're having trouble with your device, check Table 4 for possible cause and solution.

Table 4. Troubleshooting Guide

Problem	Possible Cause	Solution
No activity - circuit doesn't seem to do anything	Power supply not working, no input signal	<ul style="list-style-type: none"> • Verify DC voltage input is applied and connected OK • Check line level signal wiring
Sounds bad, muffled	Woofer/Tweeter swapped	If the woofer and tweeter driver wires get swapped, it will sound very bad, check your wiring.
60Hz audible hum, or other audible noise	Grounding problems, noise on the DC supply	<ul style="list-style-type: none"> • Make sure all you're audio source, crossover, amplifier, and any other components are solidly grounded to earth ground • Try driving the crossover with a couple of 9V batteries in series, if the hum goes away then there may be noise on your DC power supply.

Figure 3. Sub-Woofers Output, 60Hz XO Frequency , THD = 0.070%, THD+N = 0.088%

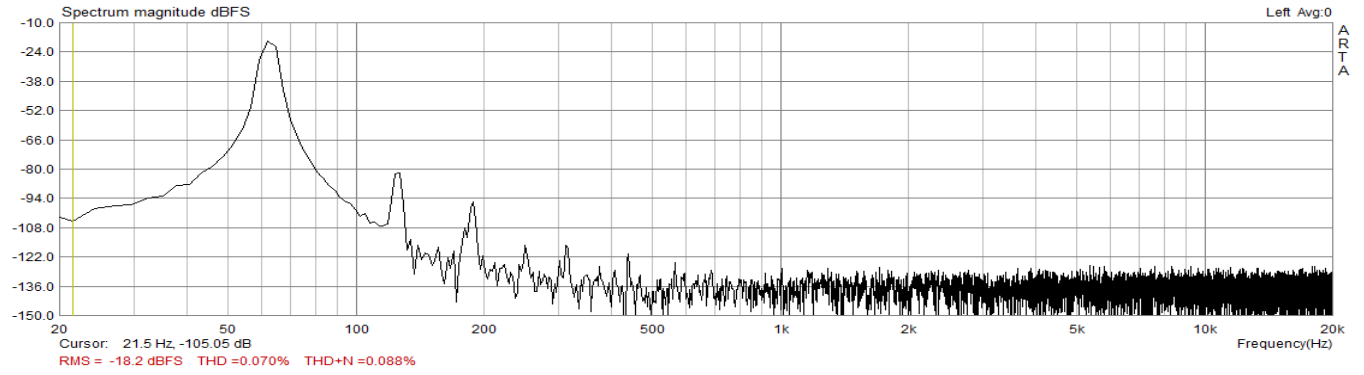

Figure 4. Mid-Range Output, 60Hz XO Frequency, THD = 0.068%, THD+N = 0.087%

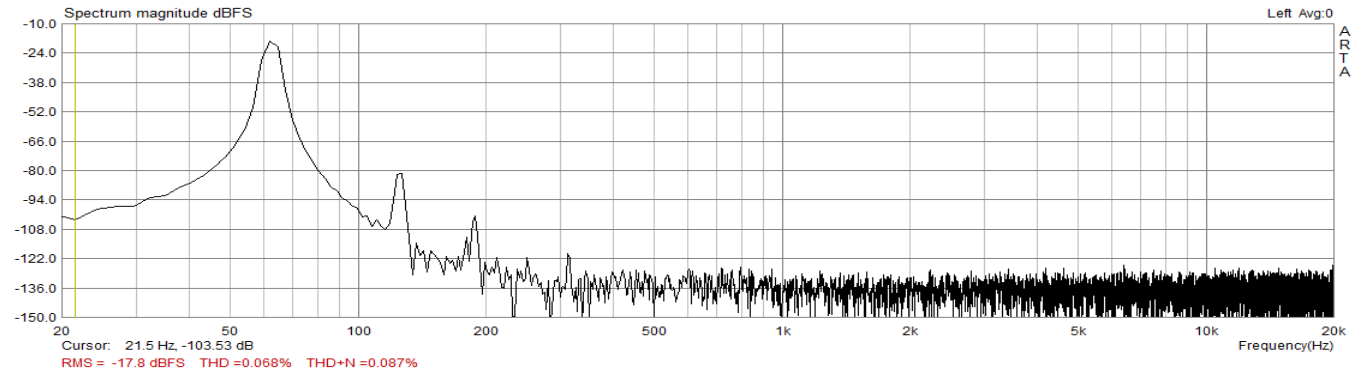

Figure 5. Mid-Range Output, 1000Hz XO Frequency, THD = 0.0013%, THD+N = 0.028%

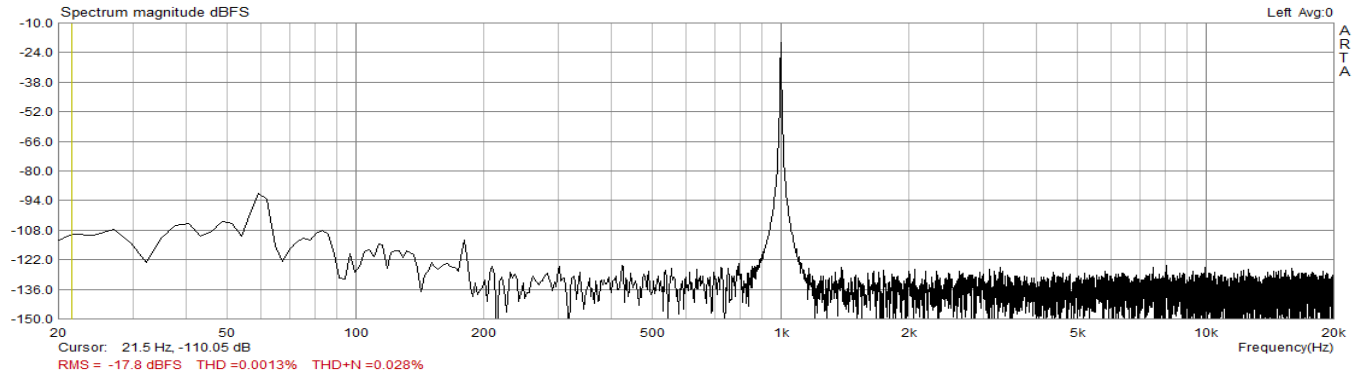

Figure 6. Tweeter Output, 1000Hz XO Frequency, THD = 0.0019%, THD+N = 0.015%

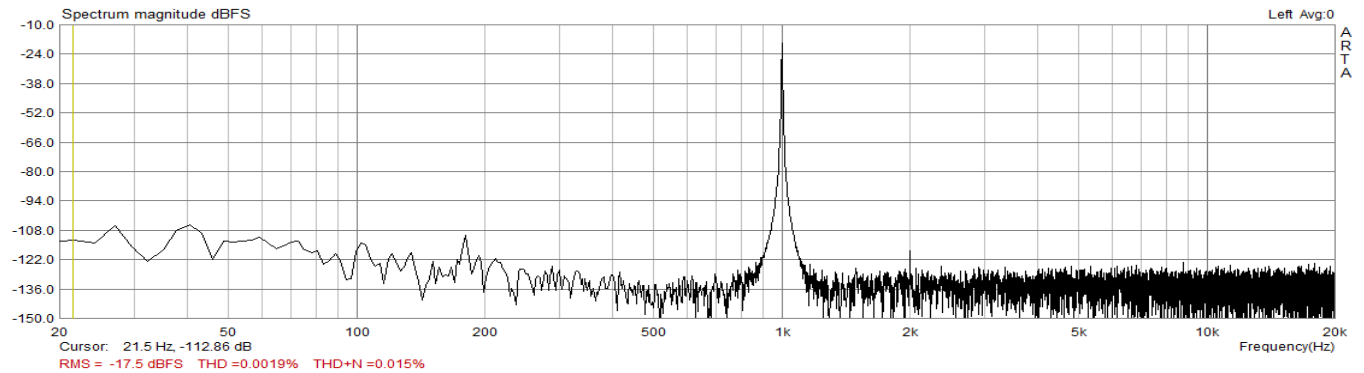

Figure 7. XOVER-3 Schematic

