

---

# 2-Way Active Crossover

## Model XOVER-2

### User's Manual

Rev 5.0

---

Xkitz.com

#### **Features**

- 2-way Active Crossover for driving separate woofer and tweeter amplifiers
- Linkwitz-Riley crossover, 4<sup>th</sup> order, 24dB/Octave roll-off
- Perfect for Bi-Amping your sound system
- Crossover frequency configuration components are on a single socketed module - quick and easy to change the XO frequency by simply snapping in a new module.
- Wide range of standard XO frequency modules are offered by Xkitz
- Baffle Step Compensation, optional, adjustable and configurable to support various baffle sizes
- Supports unbalanced signal inputs/outputs by default, support for balanced audio signaling is available as an add-on option.
  - Unbalanced signals are connected via standard RCA jacks
  - Balanced signals are connected via optional 3.5mm TRS jacks.
- Specifications:
  - THD: 0.0032%
  - THD+N: 0.0086%
  - Frequency Response: Linear from 10Hz - 80KHz
  - CMRR (balanced input): > 55dB
  - Input Impedance: 20K ohms unbalanced, 40K ohms balanced
  - Input Overload: 3.8V peak-to-peak
  - Voltage Gain: Adjustable Bass and Treble, Max 0dB Unbalanced, 12dB Balanced
  - Filter Topology: Linkwitz-Riley, Constant Voltage, 4<sup>th</sup> Order, 24dB/Octave
  - Power supply: 17V-24V DC, Single positive DC rail (no negative supply required)
  - Supply Current: 100mA
- Channels are phase aligned to within a fraction of a degree to minimize distortion near the XO frequency
- Separate bass and treble output level adjustments via on-board multi-turn trim-pots
- Filtered LDO regulator for high power supply noise rejection, ultra clean audio
- This is a mono device, two units are needed for stereo operation
- PCB dimensions: 3.5" x 2" x 0.65" height

## **What's an Active Crossover and Why Do I Need It?**

Most speaker boxes have an electronic circuit inside them called a crossover. Its job is to split the sound into frequency ranges; it sends the low frequency sounds to the woofer, and the high frequency sounds to the tweeter. This is important because each of the loudspeakers is built to produce certain frequency ranges, and they don't sound very good outside of their proper range.

In fact, loudspeakers can actually distort within their natural frequency range if they are also presented with frequencies outside their natural range. In other words if you send low frequencies to your tweeter, the high frequency sound reproduced by the tweeter will be distorted by the presence of the low frequency signal.

When you separate the frequencies with a crossover, each loudspeaker is able to focus on producing only the frequencies that they're designed to produce.

Most speaker boxes you see have **passive crossovers**, which are made up of some inductors and capacitors that filter the low frequencies from the highs. But passive crossovers have a number of very significant drawbacks. One big problem with passive crossovers is they don't have a very sharp **roll-off**. This means that some of the bass frequency energy will still reach the tweeter, and some of the treble energy will still reach the woofer. Another major disadvantage with passive crossovers is efficiency; they waste a huge amount of the power you're amplifier is providing. High frequency sounds are prevented from going to the woofer (and low frequencies prevented from going to the tweeter) by essentially just shorting them out; so power is wasted in the form of heat dissipated in the crossover components.

But by far the biggest problem with passive crossovers is that they significantly degrade the quality of the signals that pass through them by introducing distortion in the following ways:

- Channel phasing: Once the crossover splits the audio signal, the woofer and tweeter signals will be out of phase from each other (which means one leads or lags the other). This causes distortion at and around the crossover frequency because at these frequencies both the tweeter and the woofer will be driven, but each will be at a different phase. At various points of time in the wave the woofer and tweeter will be either fighting one another or re-enforcing one another. This leads to a muddying of the sound definition.
- Channel Cross-talk due to Back-EMF: The mass of the loudspeaker cones will continue to move in the direction they are being driven by the amplifier for a short period of time after the signal changes direction, and this induces currents in the voice coils that couple back into the passive crossover and causes unpredictable non-linear crosstalk between the channels of the crossover.
- Frequency response degradation: any time you put large capacitors and inductors in series or parallel with your audio signal it will invariably affect frequency response of the signals. The ways in which this can happen depend on the design of the crossover and the characteristics of the loudspeakers. The nature of this distortion is so complex it becomes almost impossible to accurately model.

All of this adds significant distortion to the final sound emitted. Audio engineers for decades have tried in vain to come up with ever more complex passive filter arrangements to try and resolve, or mask, these inherent problems.

An **active crossover**, like the XOVER-2, on the other hand, is built from the highest quality operational amplifiers (op-amps) and the filter functions are applied to the high impedance, line-level preamp input instead of the low impedance, high voltage level amplifier output. Active filters have a much sharper roll-off, 24dB/octave, allowing each of the loudspeakers to perfectly focus on producing just the frequencies they are designed to handle (see Figure 3, crossover frequency graph). Active crossovers are also more efficient from a power standpoint because of the fact that the filters are applied in the line-level audio input signal; only the energy meant for a particular driver is sent to the amplifier that drives it, so there is no waste. But the biggest advantage of active crossovers is the sound quality. A vanishingly small amount of noise and distortion is introduced in the op-amp filter circuits, on the order of 0.00005% total harmonic distortion.

All of this results in extremely clean, precise, and well defined audio output to your amplifiers.

## What is Bi-Amping?

In the pro audio community the idea of applying an active crossover to drive separate amplifiers for the woofer and tweeter is called **Bi-Amping**, specifically '**Horizontal Bi-Amping**'. Most modern professional powered speakers are Bi-Amped, because this provides scalability and extremely high fidelity sound. The idea has a great following in the DIY audio community as well, although many consider it to be out of reach to most due to the high cost of providing a specialized pre-amp with an active crossover to drive separate power amplifiers to drive the woofers and tweeters separately.

Figure 1. Dimensions

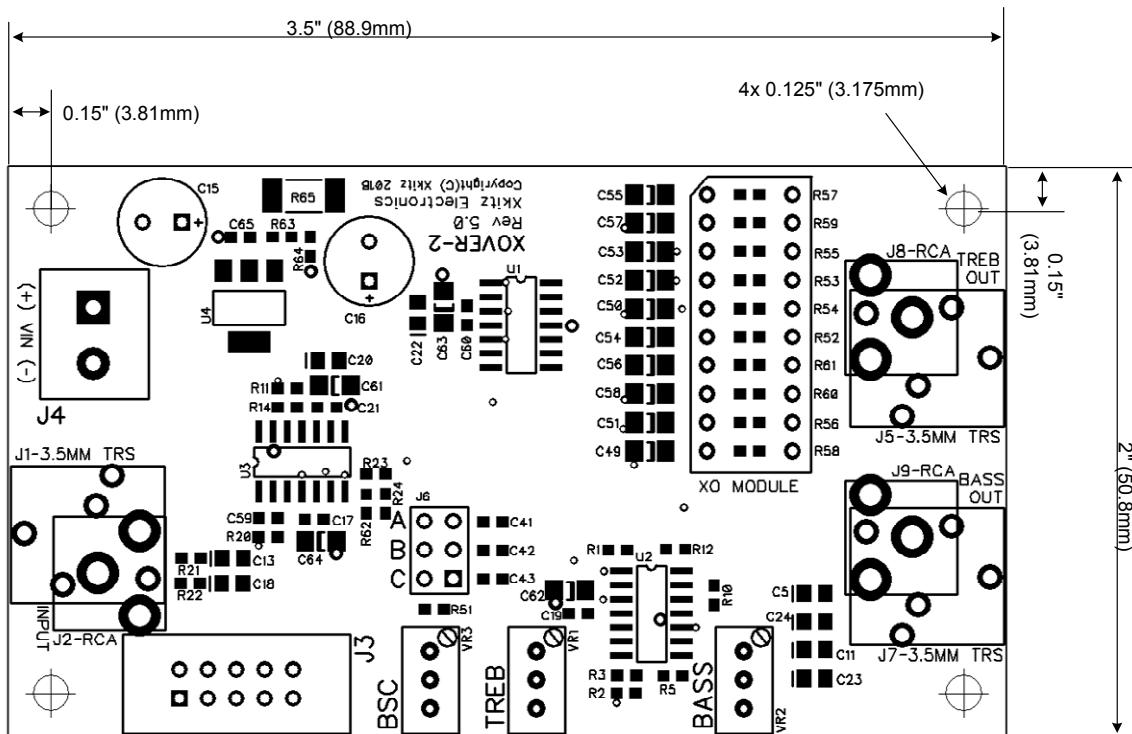

Vertical Clearance, top of board: 0.65" (16.5mm)

Vertical Clearance, below board: 0.125" (3.175mm)

## **Input Signal Configuration – Balanced or Unbalanced**

There are two basic systems used to connect the audio signal on consumer and pro audio equipment; unbalanced lines and balanced lines. Unbalanced lines use one wire for signal and the other for ground. Balanced lines, on the other hand, have two signal wires and a shield ground wire.

Unbalanced lines are most common in consumer grade audio, and are generally much more susceptible to audio noise like 50/60Hz hum. Unbalanced lines will also pick up any electro-magnetic noise in the nearby environment (such as computers, cell phones, microwaves, etc.) and adds it to your audio signal, making it audible in your speakers. Unbalanced lines can also lead to ground loops, which are the major source of 50/60Hz hum in your sound system. Ground loops arise whenever there is more than one path from any piece of audio equipment to earth ground. Your equipment will always be grounded through your AC line. Adding another path to ground through your unbalanced audio cable adds a second path to ground, and this can cause audible 50/60Hz hum.

Balanced lines are more common in high end consumer and professional audio systems and are much less susceptible to noise. Balanced lines allow you to run very long audio cables without allowing electro-magnetic noise to couple into your signal. They're also not susceptible to 50/60Hz hum; there is no connection to ground in the audio signal cable, so they can't create ground loops in your sound system.

For balanced connection, a 3.5mm TRS jack will be installed. For unbalanced, an RCA jack will be installed.

## **Output Signal Configuration – Balanced or Unbalanced**

The TREB and BASS output signals can also be configured to drive either balanced or unbalanced outputs.

For unbalanced signal outputs, RCA jacks will be installed. For balanced, 3.5mm TRS jacks will be installed.

For balanced signal outputs, you'll install two 3.5mm TRS jacks in locations J5 and J7, and leave location J8 and J9 empty.

**Figure 2. Balanced Mode signal Input and Output TRS Jack Wiring**

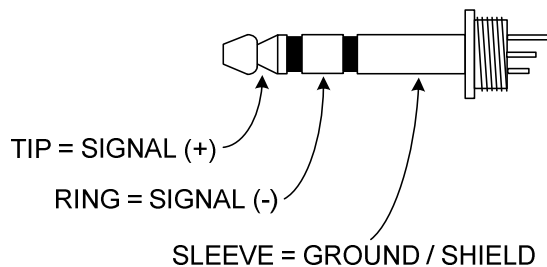

## **Auxiliary Input Connector**

The board has a 2x5 auxiliary input connector that you can use to access the balanced audio signal input pins. You can use this connector to drive the balanced inputs from a ribbon cable, or to hardwire the balanced inputs. You can also provide power to the board through this connector. The pin-outs of J3 connector are as follows:

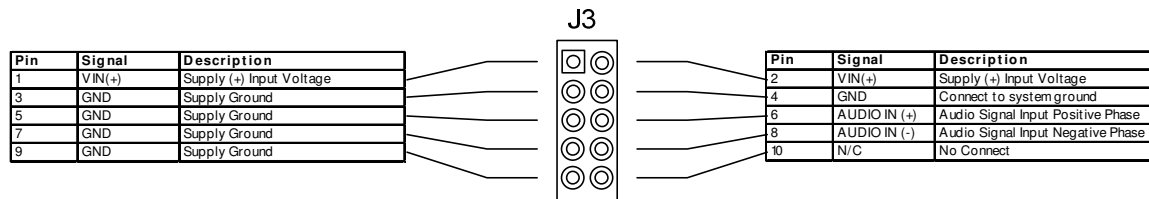

## **Customizing Your Active Crossover Frequency**

The crossover (XO) frequency is determined by the value of the ten resistors mounted to a 20-pin socketed component carrier called the 'XO Module'. All 10 resistors are set to the same value.

Xkitz offers a wide range of standard XO Module frequencies at this location:

<https://www.xkitz.com/collections/active-crossovers-and-bi-amplifiers-1/products/xo-module-for-use-with-over-2-and-xamps>

Or you can select your own custom XO frequency resistor values with our filter calculator tool at:

<http://www.xkitzconnect.com/files/Linkwitz-Riley-2Way-Calculator.htm>

Just enter your desired crossover frequency. Then hit the 'Calc' button. It will give you the suggested resistor value for your crossover, and it will show a schematic diagram of the crossover. You may have to round the suggested values to standard available resistor values. High precision (1% or better) resistors are recommended to minimize distortion.

## **Selecting Your Ideal Crossover Frequency**

Consult the specifications of your loudspeakers to select your ideal XO frequency. Every loudspeaker has its own ideal operating frequency range. Woofers, of course, work well in the low frequency range, but as frequency increases their performance deteriorates. Same for tweeters; they operate well at upper frequency ranges and deteriorate as the frequency comes down. Your crossover frequency should be somewhere near the mid-point between points where both the woofer and the tweeter are still solidly within their ideal operating frequency range.

## **Power Supply Requirements**

The XOVER-2 requires a DC voltage source in the range of 17V up to 24V max. Even though the board has an LDO voltage regulator that will filter out most noise from your input power supply, you should try to select a power supply with a clean DC output to ensure you're audio is clean.

The XOVER-2 draws less than 100mA from the supply.

## **Baffle Step Compensation (BSC)**

The Baffle Step Compensation circuit, or BSC, if you choose to use it, allows you to apply a low pass filter function to the audio signal to compensate for a phenomenon where sounds above a certain frequency (determined by the size of the baffle, or the front of your speaker box) are actually reflected by the front of the speaker enclosure. Sounds that fall below that frequency do not get reflected, but instead wrap around the back of the speaker enclosure. This has the effect of reducing the magnitude of the lower frequencies. Your ear hears the primary waves plus the reflected waves on the highs, but only the primary waves of the lows. The BSC circuit, by applying a low pass filter, will roll off some of the highs to restore the overall sound to a more natural, linear state. Check the web for more detailed description of BSC.

The VR3 precision 20-turn trim-pot allows the BSC magnitude to be adjusted. Turning the pot 20 full revolutions counter-clockwise reduces the BSC magnitude to the point of being entirely disabled. Turning it clockwise increases the BSC magnitude to a maximum of 6dB. In other words, it increases the amount of attenuation of the higher frequencies to 6dB below the lower frequencies. This compensates for the theoretical 6dB attenuation of the low frequencies due to the baffle step.

**Table 1. Baffle Step Compensation – Recommended C42 Value**

<b>Baffle Width (in Inches)</b>	<b>Baffle Step Freq.</b>	<b>J6 Jumper Setting</b>
Less than 10"	507Hz	"A"
10" - 16"	351Hz	"B"
Greater than 16"	240Hz	"C"

## **Initial Power-up and Calibration**

Before applying power for the first time, it's a good idea to make sure the bass, treble and BSC are fully disabled. The trim-pots are high precision, 20 turn pots, so in order to ensure the bass, treble and BSC are fully OFF you need to turn all three trim-pots 20 full revolutions counter-clockwise.

There are a number of different methods to calibrate a 2-way active crossover. Below is the method we generally prefer. We like to first set the bass level to roughly unity gain (output level same as input) using a voltmeter or an oscilloscope, then gradually raise the level of the high channel and set the ideal level exclusively by ear or a spectrum analyzer. There is generally a large difference in the efficiencies of woofers and tweeters, so there is no ideal ratio between the bass and treble levels. Using this method, you end up with an overall insertion gain of roughly 0dB, and you can easily reach an ideal balance between drivers with differing levels of efficiency.

In a stereo system, you'll want to try and calibrate both L and R at the same time to maintain a close balance of the L and R volume levels.

1. Use a signal generator of some kind to inject a sine wave into the crossover. Free signal generator apps are widely available for any smart phone or on the PC. Either connect it directly to the input of the crossover, or if your crossover is part of your larger system, simply connect it to any line input and select it to drive the crossovers.
2. Set the level of the signal generator (or the volume of your system) to maximum volume.
3. Set the frequency of the signal generator to around 50Hz.
4. Using a voltmeter or oscilloscope, measure the signal level of the crossover's input signal(s). For unbalanced inputs, just unplug the RCA jack from the crossover and measure the voltage across the inner and output contacts of the cable jack. For balanced input(s), unplug the TRS jack and measure across the TIP and RING conductors (see Fig 2 above). Plug the jack back into the crossover.
5. Begin raising the level of the Bass channel while monitoring the crossover Bass output. Again, measure across the RCA jack contacts or the TIP and RING for unbalanced or balanced modes. Raise the Bass level until the output voltage is equal to the input voltage from step 4.
6. Now that you have your bass channels set to 0dB gain, it's time to set the crossover Treble level. Connect your normal audio signal source and set the volumes to a comfortable listening level. Either use a spectrum analyzer (free smart phone or PC apps are available) or just use your ears to monitor

the audio from your speakers. Since the Treble level is set to zero, the sound will start out dull and lacking in any high frequencies. Slowly raise the Treble level control pot until your treble level is flat on the spectrum analyzer, or until it sounds natural by ear. You may want to adjust the L and R in isolation so that you can make sure both are dialed in properly, without the other channel interfering.

- Now slowly raise the BSC pot until your bass response sounds natural, or the lows below the baffle step frequency look flat on the spectrum analyzer (see table 3).

## Troubleshooting

If you're having trouble with your device, check Table 2 for possible cause and solution.

**Table 2. Troubleshooting Guide**

Problem	Possible Cause	Solution
No activity - circuit doesn't seem to do anything	Power supply not working, no input signal	<ul style="list-style-type: none"> <li>Verify DC voltage input is applied and connected OK</li> <li>Check line level signal wiring</li> </ul>
Sounds bad, muffled	Woofers/Tweeters swapped	If the woofer and tweeter driver wires get swapped, it will sound very bad, check your wiring.
60Hz audible hum, or other audible noise	Grounding problems, noise on the DC supply	<ul style="list-style-type: none"> <li>Make sure all your audio source, crossover, amplifier, and any other components are solidly grounded to earth ground</li> <li>Try driving the crossover with a couple of 9V batteries in series, if the hum goes away then there may be noise on your DC power supply.</li> </ul>

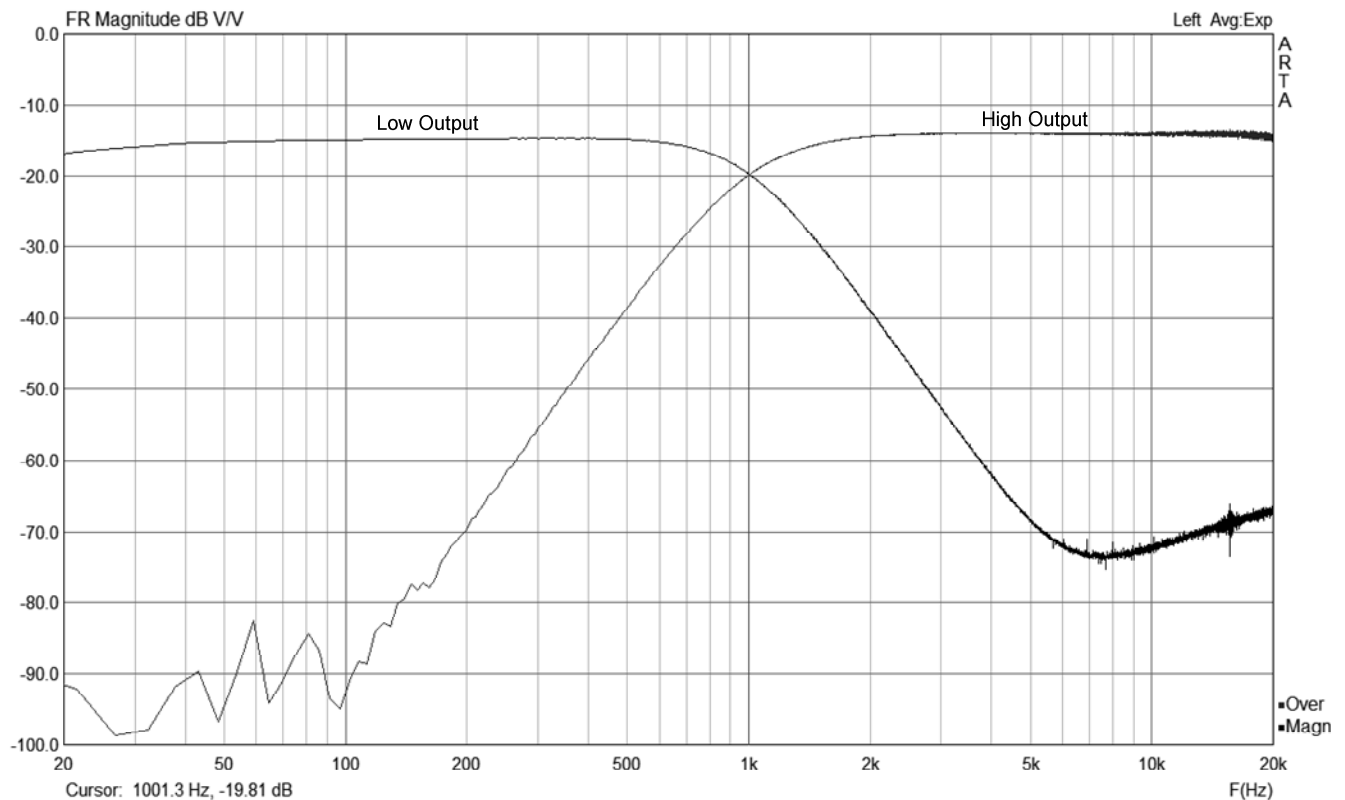

**Figure 3. Crossover Frequency Response – 1KHz XO Configuration**

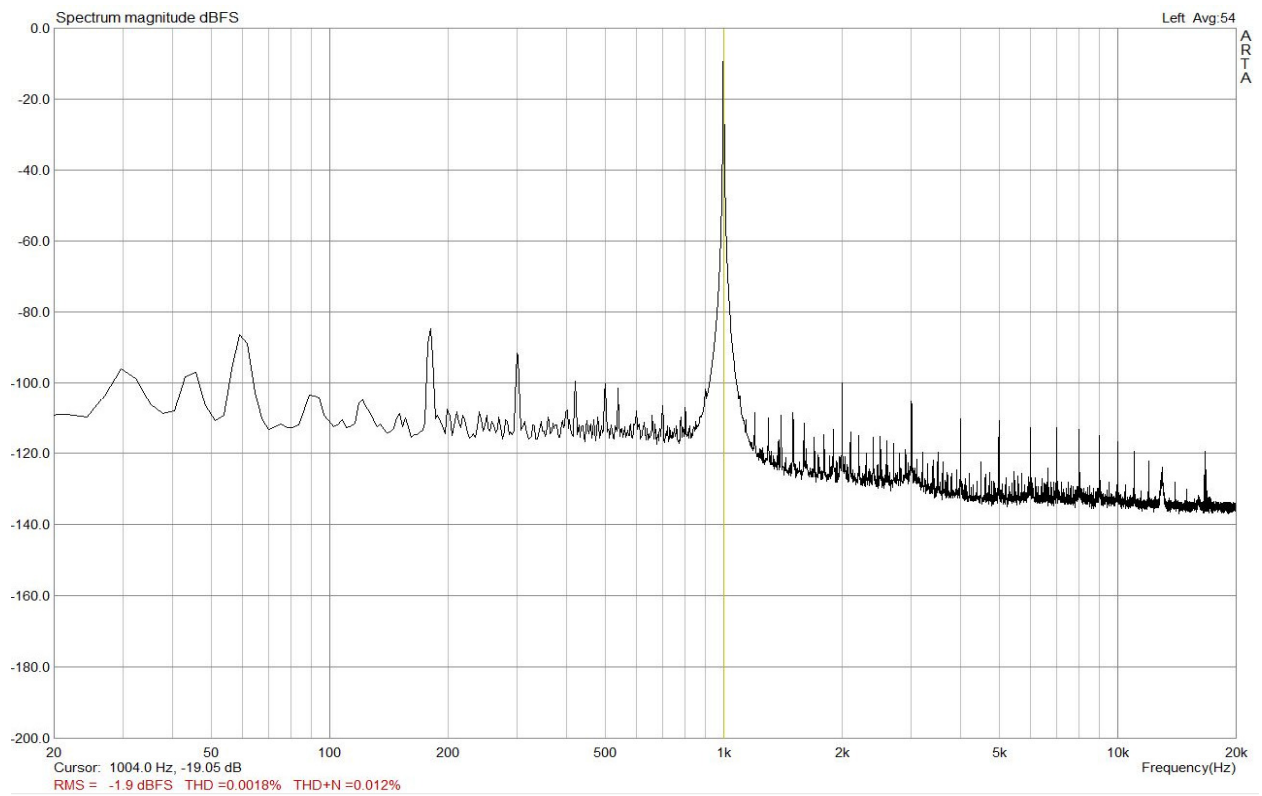

**Figure 4. THD and THD+N for Low Output**

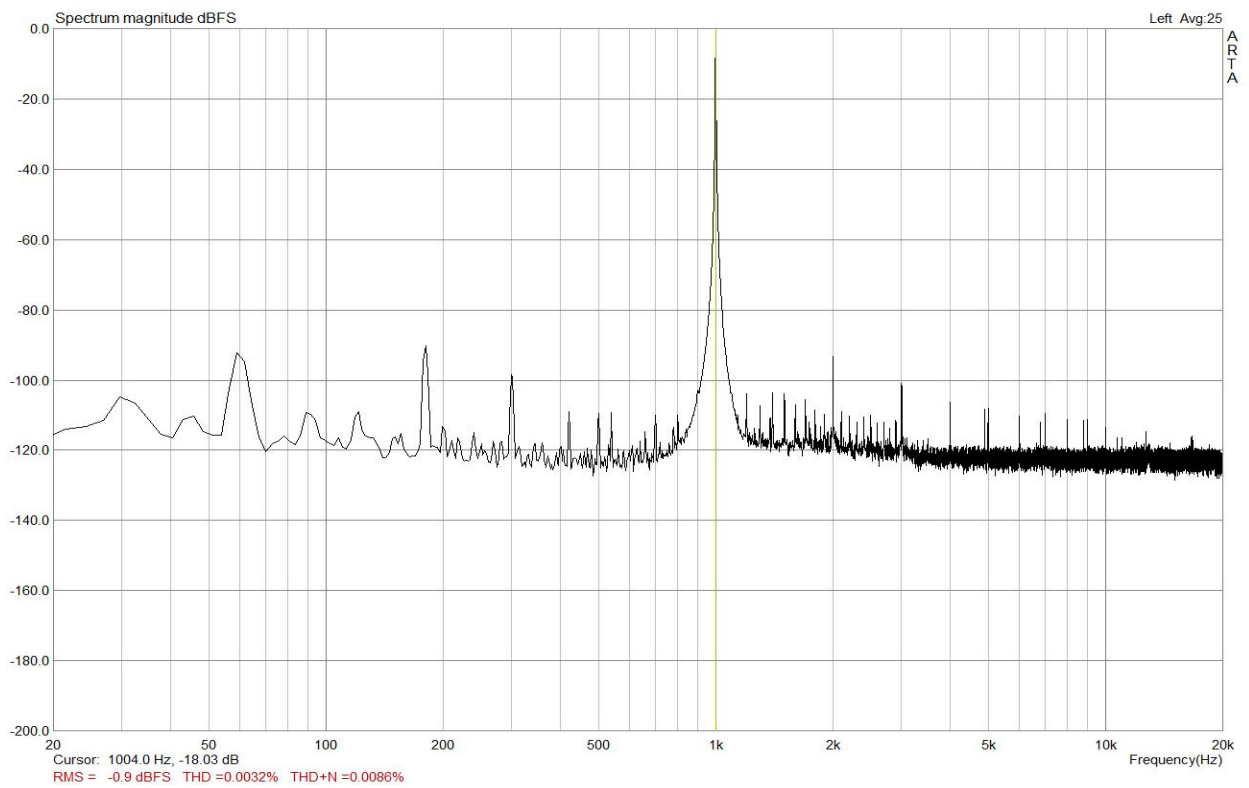

**Figure 5. THD and THD+N for High Output**



**Figure 6. XOVER-2 Schematic**

