8 Channel Capacitive Touch Switch

Model XCTS-8M

Operators Manual

Xkitz.com

Invisible Touch Switch:

The XCTS-8M allows you to install up to 8 capacitive touch switches nearly anywhere. It detects any sudden change in the capacitance on the 'Touch Plates' that results from human touch. The Touch Plates can be hidden behind any non-conductive overlay material like glass, Plexiglas, tile, wood, plastic, drywall, granite, etc. The output circuit will be actuated when that area of the overlay is touched. When touch is detected, it sources a DC voltage on the 'Load' output.

Details:

- 8 Capacitive Touch detection circuits, each controls one high current DC output
- No moving parts to wear out or corrode over time – makes a very reliable alternative to mechanical switches
- The sensitivity of the Touch Sense circuitry is adjustable per channel to support a wide range of applications
- Housed in a sturdy ABS plastic enclosure with mounting flanges
- Switch action modes supported:
 - Toggle switch
 - Momentary contact switch
 - Radio Button mode
- Create your own custom touch plates using any conductive material such as copper tape, copper clad board, or virtually any other conductive object
- Power supply requirements:
 - 6V DC min.
 - 30V DC max.
 - Current capability sufficient to drive the total of all output loads plus 15mA
- Output Load drive characteristics:
 - DC output voltage is equal to the power supply voltage
 - 20 Amps max total output current, all channels combined
 - Fuse protected
- Plastic Enclosure Specifications:
 - Sturdy, Black, Flame Retardant ABS
 - Flame Rating: UL94-5VA
 - 4.2" x 2.8" x 1" in height (excluding mounting flanges)
 - Two Mounting Flanges with .19" mounting holes
- For use in moisture free environments. Moisture on the touch sense surface will degrade touch sense performance
- Applications:
 - Any application that calls for pushbuttons or toggle switches
 - Install invisible switches – hidden behind any non-conductive surface like plastic, wood, drywall, etc.
 - Automotive Touch Switches
 - Replacement of mechanical switches with reliable solid state Capacitive Touch switches
 - Proximity switches - sensitivity can be set high enough to detect the *nearby* presence of a person, animal, or any other any conductive or semi-conductive object or material.
 - Moisture sensor switches - this circuit can remotely detect the presence of moisture nearby, without having to come in direct contact with the moisture itself.
- Sold fully assembled and ready to install
- **Warning:** May be susceptible to RFI or EMI interference. Not suitable for life critical applications

Overview:

The XCTS-8M combines eight highly sensitive ‘Capacitive Touch Sensors’ with eight corresponding high current DC switches. It constantly monitors the capacitance measured on attached metal electrodes called the ‘Touch Plates’ and can detect infinitesimal fluctuations that result from people or conductive objects coming into proximity of the touch plates. Touch is detected when a sudden increase in capacitance is observed. The selected high current DC switch is actuated in response to touch detection.

Switch Action Modes:

The switch action mode can be selected via jumper setting:

- Toggle Switch mode - the output is alternately activated and deactivated for each touch detection cycle.
- Momentary Contact mode - the output is activated only while touch is detected.
- Radio Button Mode – Only one output is activated at any time, when a new circuit is activated, the previous active circuit will be deactivated.

Sensitivity Adjustment:

The eight small trim-pots on the XCTS-8M control the touch detection sensitivity of each of the eight channels. Turning clockwise increases the sensitivity. The Status LED blinks red while you’re turning the pot, then blinks green twice when you stop turning to indicate the system has been recalibrated based on the new trim-pot setting.

You have the option of setting each channel to a different level of sensitivity, or you can set the sensitivity of all channels with a single pot. Use the Single Pot Mode to simplify adjustment if all your touch plates have identical characteristics (plate diameter, overlay thickness, etc.). If your touch plates have various different characteristics, select the Multi Pot Mode to allow each channel to be adjusted individually.

Status LED:

There is an LED on the XCTS-8M that indicates the current system status. It can illuminate either in red or green, solid or blinking:

LED Status	Description
Off	System is stable
Solid RED	System is stable, Touch is currently detected on one or more channels
Blinking GREEN	System calibration is in progress, occurs after power up, after trim-pot adjustment, and after a change of jumper setting
Blinking RED	Trim-pot movement is detected

Channel Status LEDs:

Each of the eight output channels has a separate green status LED. The LED will be illuminated when the output Load is activated.

Option Jumpers:

The operating mode is selected by the configuration of six jumper shunts, shown in the table below.

Jumper	Mode Select	Shunt Out	Shunt In
JP1-JP8	Channel 1-8	Toggle Switch	Momentary
JP9	Radio Button Mode	Yes	No
JP10	Pot Mode	Single	Multi

Wiring and Installation:

Connection to Power Supply:

The XCTS-8M requires an input voltage in the range of 6V-30V DC, with current capability sufficient to drive the all the output loads plus 15mA. It is recommended to use a clean, good quality power supply. Linear supplies are preferred because they generally produce the cleanest DC voltage. Switching supplies can sometimes produce high frequency noise on the DC voltage, which can in some cases interfere with the operation of the XCTS-8M.

See Fig. 2 System Level Wiring diagram below for power supply connection info.

Earth Grounding:

Some applications will benefit from earth grounding the system. Generally speaking, any application that is powered from a DC power supply sourced from AC mains should be earth grounded. Battery powered applications generally don't need earth grounding, or can be supported by adding a ground plane around the touch plate.

Earth grounding significantly increases the signal-to-noise ratio of the detection circuits. See Fig. 2 System Level Wiring diagram below for info on how to connect the earth ground.

Connection to DC Output Load:

Connect the DC Loads as shown in Fig. 2 System Level Wiring diagram below. It's OK to leave unused output circuits unconnected.

Touch Plate Connection:

In order to detect touch, the XCTS-8M must be connected to some form of 'Touch Plates'. This can be nearly any conductive metal object, but will normally take the form of a flat piece of copper affixed behind an insulating overlay material.

Many applications will benefit from adding a second, adjacent ground plane near, or preferably completely surrounding each of the touch plates. This greatly increases the signal-to-noise ratio of the capacitance measurements.

Use the included ribbon cable to connect your touch plates. The cable plugs into the keyed connector on the controller board. The cable is wired in 8 pairs of Touch Plate/Ground Plane wires for each of the 8 channels. The shaded wire on one edge of the cable is the wire for the Ch1 Touch Plate. The next wire in the cable is the Ch1 Ground Plane, followed by Ch2 Touch Plate, etc. It is recommended to split the cable lengthwise into the eight Touch Plate/Ground Plane pairs and route each pair to the corresponding touch plate. Solder, or otherwise connect the Touch Plate wire to your touch plate, and if you're using a ground plane, solder the Ground Plane wire to your ground plane. If you're not using a ground plane, just cut the Ground Plane wire near the touch plate and leave it unconnected.

Note that you may get false activations when you touch the connecting wire. This is expected, so you should route and tack down the wire where it will be least susceptible to false activation.

For best results, the length of the touch plate connecting wire should be minimized. Longer wires become increasingly susceptible to ambient electrical noise and decrease the detection signal-to-noise ratio. In practice, installations with wires up to 2-3' long should be able to be made reliable.

Create Your Own Touch Plates:

You can make your custom touch sense plates in almost any size, shape and configuration. Nearly any conductive material such as copper foil tape, which is available in any hardware store, can be used. Or any conductive material or small metal objects will work as well. The plates or objects just need to be wired to the controller using the guidelines below.

Figure 2 System Wiring Diagram below shows how the touch sense plates and the optional ground planes are wired. Simply connect the touch plates to the controller using the insulated connecting wire. Here are some guidelines:

- The touch plates must be electrically isolated from ground, or any other metal object.
- The overlay material must be non-conductive.
- The minimum size of the plates is dependent on the thickness of the overlay material: the thicker the overlay, the larger the plates need to be. As a rule of thumb, the plate diameter should be at least 2 to 3 times wider than the thickness of the overlay material for reliable operation. This is an area you can experiment with.
- The plate size is also limited by the length of the wiring to the controller. The longer the wire the larger the plate will need to be to overcome noise picked up by the longer connecting wires. Connecting wire length up to about 12" works very reliably with .625" diameter touch plate. Connecting wire lengths up to 3' have been tested and work well with a plate that is 1.25" in diameter. (1/8" overlay thickness)
- The maximum size of the plates is something you can experiment with. Xkitz has tested plates larger than 20" square with no degradation of performance. Larger plates will generally give you a higher level of sensitivity and a longer range of detection, which can sometimes lead to false activations. In other words, you may see that the circuit detects the presence of hands *nearby* the touch plate, as opposed to actually touching the overlay material. If you experience this behavior, you can fix it by turning the sensitivity lower until the circuit detects only physical touch of the overlay material.

Initial Power Up and Testing:

Prior to initial power up, turn the trim-pot(s) fully counter clock-wise to select the lowest sensitivity setting. It's generally a good idea to double check all your connections. Use a multi-meter to verify you have no short circuit across the DC input voltage or the output Load.

Apply power to your system. You should see the green LED blink a few times while the XCTS-8M is calibrating itself. Once the LED stops blinking (which should be within 1-2 seconds), you can test the touch sensor by touching one of the Touch Plates. You should see the output Load is actuated by this touch. The status LED should illuminate red, the appropriate channel status LED should illuminate, and the output Load should be activated.

Sensitivity Adjustment:

Once you have your touch sense plates in place and wired to the controller, you need to adjust the touch detection sensitivity. Do this by slowly turning the sensitivity adjustment trim-pot clockwise(s), which increases the detection sensitivity, until you reach the point where touch is detected reliably for your sense plate/overlay material. Keep hands and other objects away from the touch sense plates and connecting wires while adjusting the sensitivity to prevent calibration errors. The LED will flash red while you're turning the trim-pot. When you stop turning the pot, the LED will give 2 final green flashes to indicate the new setting has been accepted and the system has calibrated to this new value.

It's generally best to set the sensitivity to the lowest level that will still allow proper activation. This reduces the likelihood of false activations from ambient electrical noise.

Troubleshooting Guide:

Problem	Possible Cause	Solution
No activity – The status LED doesn't blink on power up	Power supply may not working	Verify your input voltage is applied and connected properly. Use a multi-meter to confirm your input voltage is present on the green terminal block.
Erratic Operation, or random activation, or touch not detected	Bad connection to sense plate	The signal to detect touch is extremely sensitive. Poor contact between the XCTS-8M and the touch sense plate and/or the ground plane can cause erratic operation.
	Sensitivity may be too high	Turn the trim-pot counterclockwise just a bit. Wait a few seconds then check for proper operation, repeat if necessary.
	Ambient electrical noise	Heavy machinery on the AC mains, or cell phones, etc. can emit electrical noise that can interfere with the proper operation of the touch detection circuitry. Try moving the XCTS-8M further away from any possible noise sources.
	Noisy power supply	High frequency noise on the power supply (as can be caused by a switching power supply) can occasionally interfere with the proper operation of the touch detection circuitry. Try a different power supply, or a battery, and see if performance improves.
	Touch Plate connecting wire too long	Try a shorter connecting wire and see if performance improves
	Needs ground plane to be added	Erratic behavior generally arises from low signal-to-noise ratio. You can greatly increase your SNR by adding a ground plane.
	Needs to be earth grounded	Earth grounding your power supply will also greatly increase your SNR. See Fig 2 below for earth grounding info.
Touch detection works but not always, sometimes touch is missed	The sensitivity may be set too low	Turn the trim-pot clockwise just a bit. Wait a few seconds then check for proper operation, repeat if necessary.
	Overlay material too thick or Touch Plate too small	The Touch Plate diameter should be at least 2-3 times the thickness of your overlay material for reliable operation. Try increasing the diameter of the Touch Plate
	Signal-to-Noise Ratio too low	Increasing your SNR will allow you to turn the sensitivity higher without leading to erratic behavior. Either add a ground plane near your touch plate, and/or earth ground your power supply to increase your SNR
Red LED stuck ON, regardless of touch being detected	The sensitivity may be set too high.	Turn the trim-pot counterclockwise just a bit. Wait a few seconds then check for proper operation, repeat if not.
		See 'Erratic Operation' above for other possible solutions
Switch circuit 'bounces', or exhibits multiple switch closures per touch	The sensitivity may be set too high.	The sensitivity should be set just high enough to detect touch. When the sensitivity is set too high, the circuit will detect when something is <i>approaching</i> the touch plate, and may bounce during this time. Turn the trim-pot counterclockwise just a bit. Wait a few seconds and check for proper operation, repeat if necessary.
		See 'Erratic Operation' above for other possible solutions
Touch sense and LED operate correctly, but output Load won't activate	The fuse may be blown	Check the fuse, replace if necessary. Use a maximum 20 Amp fuse, size 1AG

Figure 1. Connection and Jumper Quick Reference

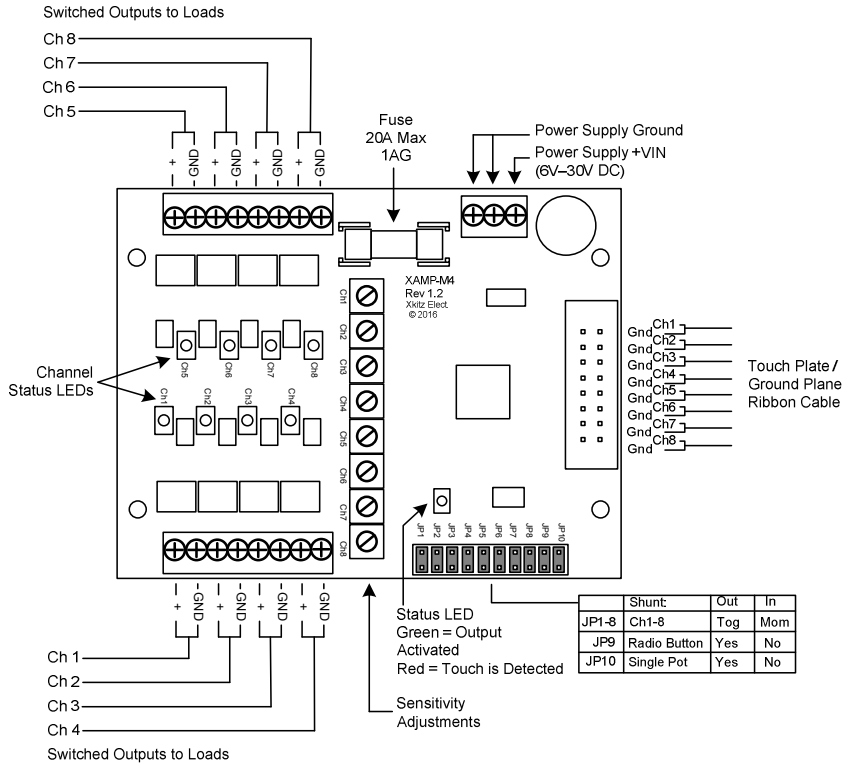

Figure 2. System Wiring Diagram

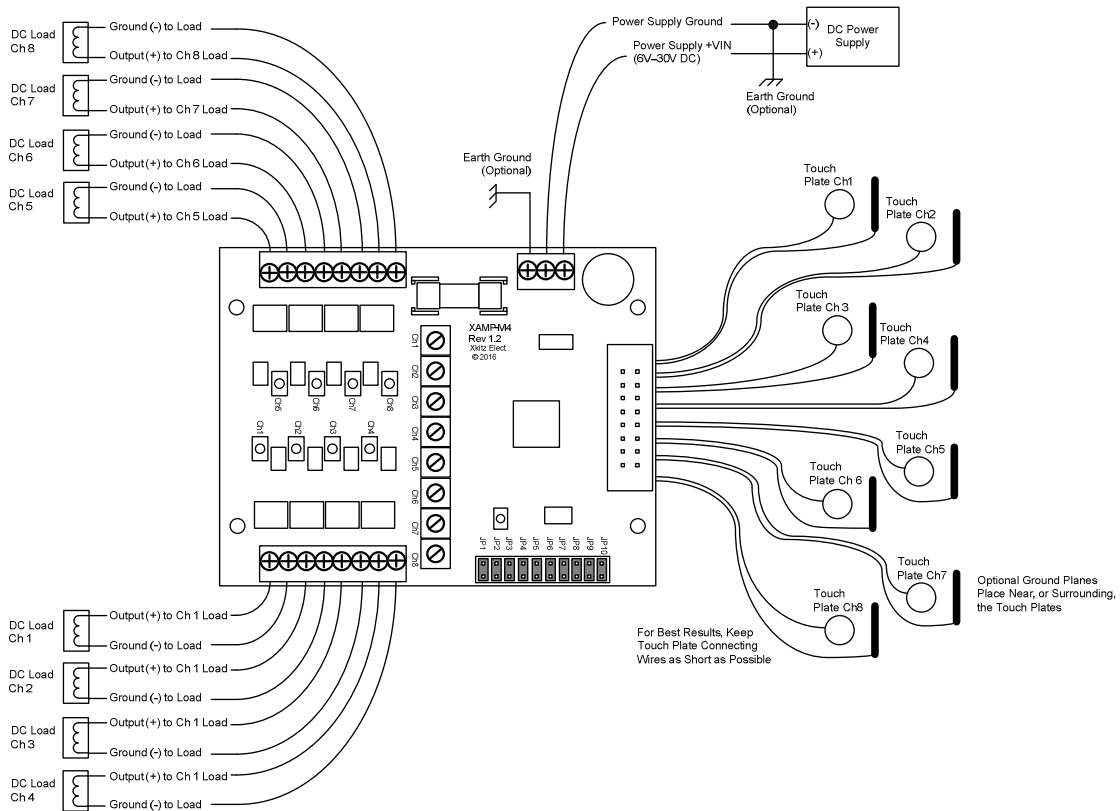

Figure 3. Enclosure Dimensions

